

## CS 300/3 POMPĂ CENTRIFUGALĂ

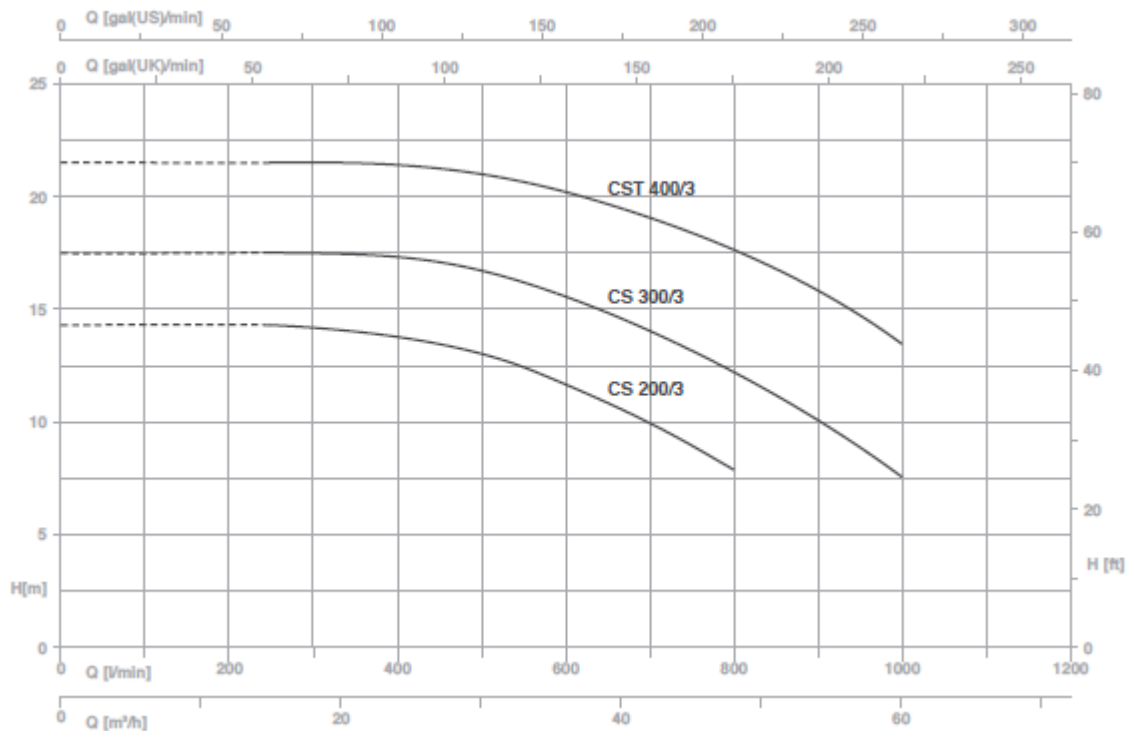



Putere absorbită P1:	3.3 kW
Putere P2:	2,2 kW
Alimentare:	230 V / 50 Hz
Inălțime maximă de refulare:	17.5 m
Debit maxim:	60000 l/h
Diametru de aspirație:	3"G
Diametru de refulare:	3"G

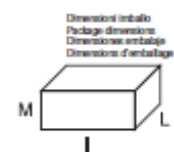
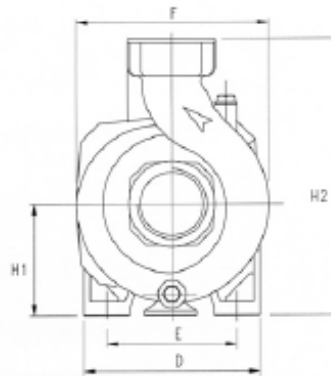
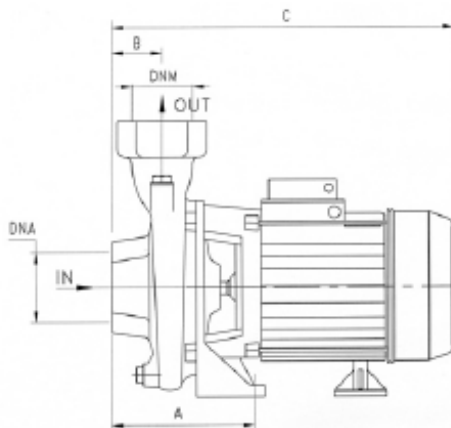

Debit Q (m <sup>3</sup> /h - l/min)					
0	15	24	36	48	60
0	250	400	600	800	1000
Înălțime de refulare H (m)					
17.5	17.5	17.2	15.3	12.3	7.5

Temperatura maximă a apei:	90°C
Carcasă pompă:	fontă
Suport motor:	fontă
Rotor pompă:	fonta/bronz
Etanșare mecanică:	ceramică – grafit
Arbore motor:	otel AISI 303
Clasă de izolație:	F
Clasă de protecție:	IP44
Protecție termică:	Da



TYPE	DIMENSIONS (mm)													
	A	B	C	D	E	F	H1	H2	DNA	DNM	I	L	M	
CS 75/2	127	45	315	155	115	178	97	247	2" G	2" G	340	195	280	14.2
CS 100/2	127	45	315	155	115	178	97	247	2" G	2" G	340	195	280	15.5
CS 150/2	150	53	370	180	140	218	115	285	2" G	2" G	390	230	325	23.3
CS 200/2	150	53	370	180	140	218	115	285	2" G	2" G	390	230	325	24.3
CSB 100/2	130	70	365	180	130	195	90	240	2" G	2" G	390	230	325	18.2
CSB 150/2	130	70	365	180	130	195	90	240	2" G	2" G	390	230	325	19.1
CS 200/3	176,5	80	455	200	140	225	112	292	3" G	3" G	480	245	330	28.3
CS 300/3	176,5	80	455	200	140	225	112	292	3" G	3" G	480	245	330	31.5
CST 400/3	176,5	80	455	200	140	225	112	292	3" G	3" G	480	245	330	31.6
CST 450/4	165	85	480	220	160	250	130	330	4" G	4" G	510	275	365	41.1
CST 550/4	165	85	480	220	160	250	130	330	4" G	4" G	510	275	365	41.1